

LOC	DIST	REVISIONS					
AF	50	P	LTR	DESCRIPTION	DATE	DWN	APVD
		J		REVISED PER ECR-06-010423	21SEP06	HMR	KR

- 1 CONTINUOUS STRIP ON REELS WITH TERMINALS LOCATED ON 8.38 ± 0.08 [$.330 \pm .003$] CENTERS
- 2 SLOT ACCEPTS 0.57-0.81mm [#23-#20] AWG COPPER MAGNET WIRE. TWO WIRES OF THE SAME SIZE MAX PER SLOT FOR #23 GAGE. ONE WIRE MAX PER SLOT FOR #22-#20 AWG
- 3 IDENTIFICATION NUMBER 15 FOR THE MAGNET WIRE SLOT SIZE
- 4 0.25[.010] MAX CARRIER CUT-OFF TABS

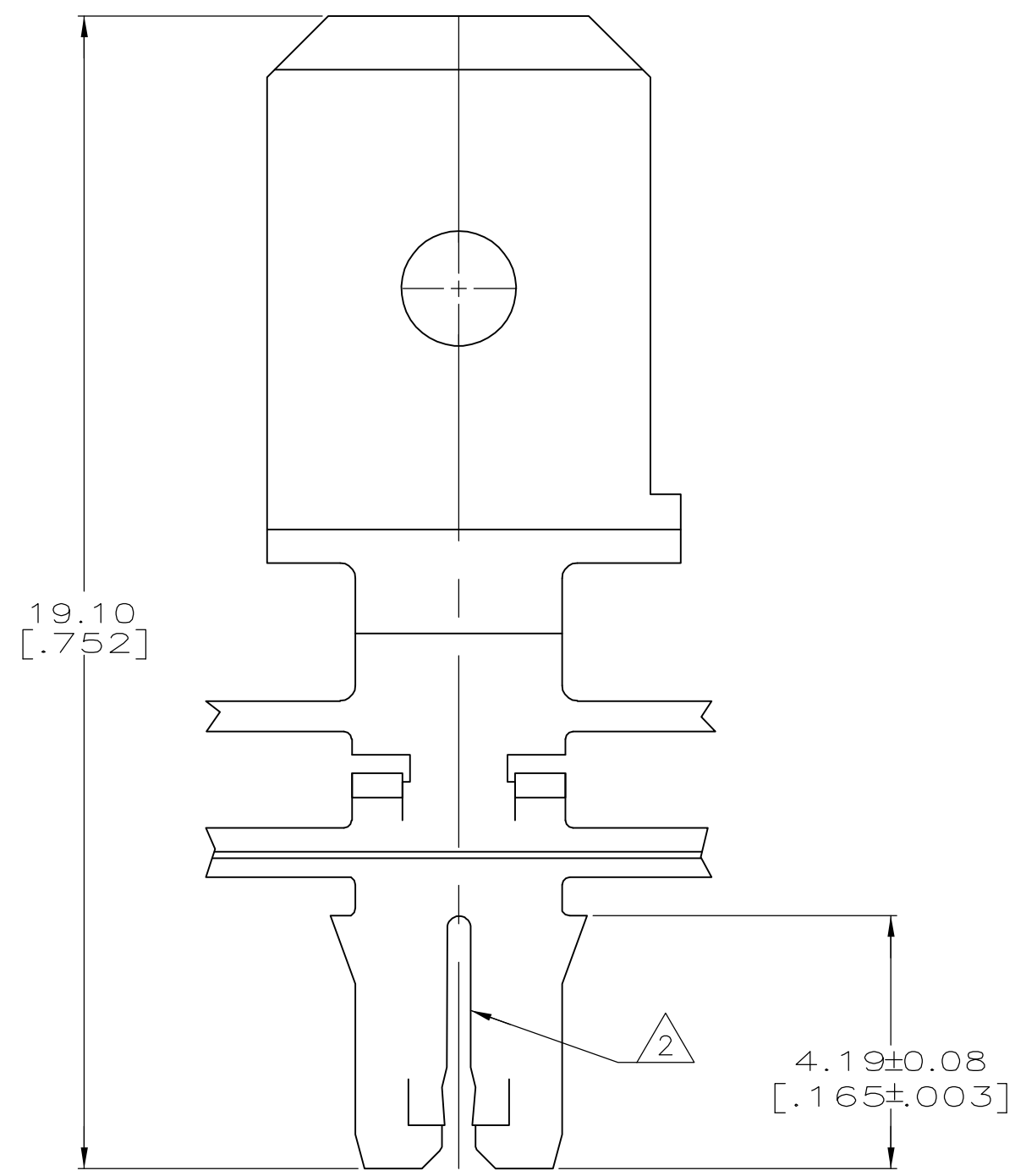
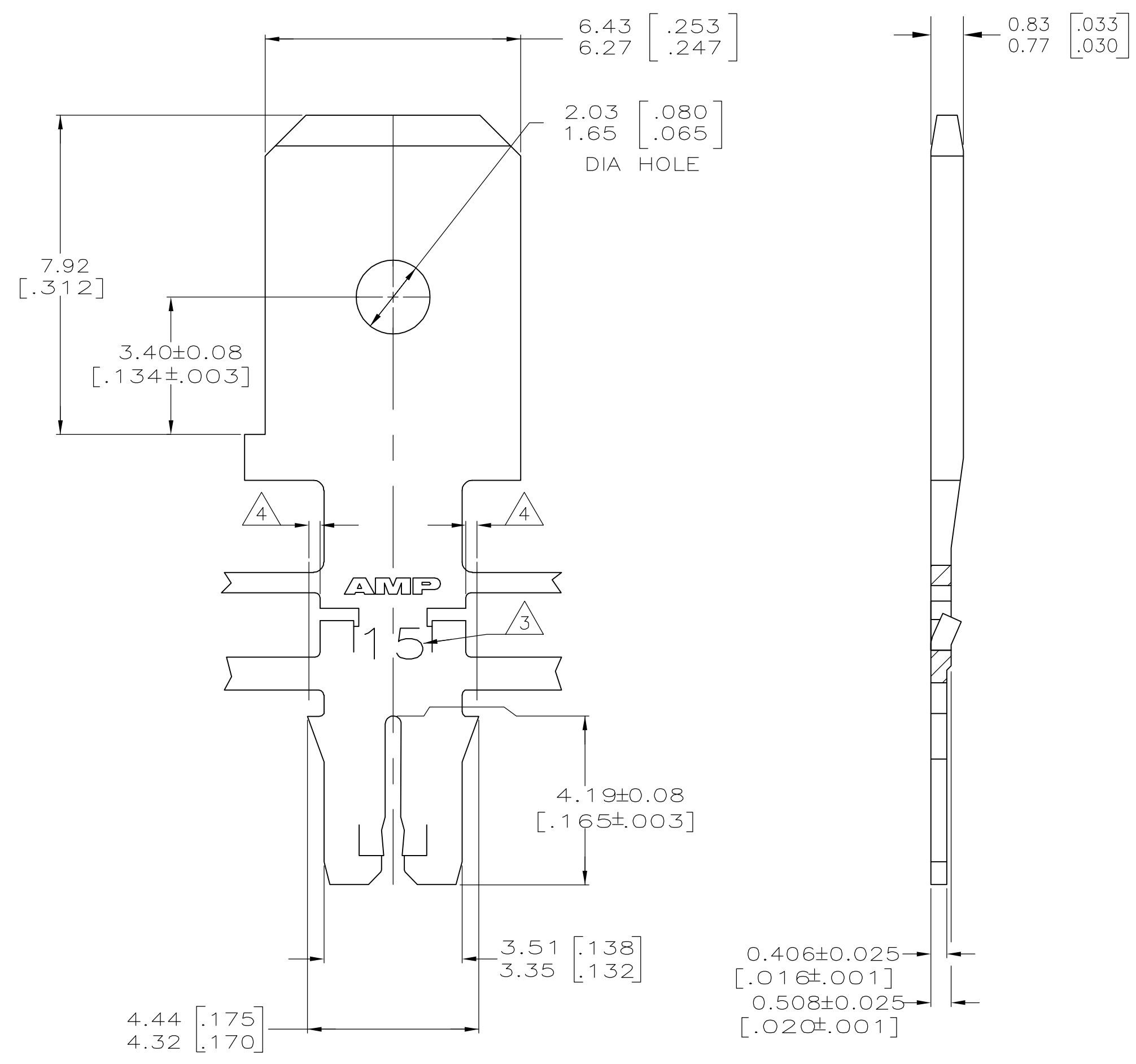

OBSOLETE	082 PRE-MILLED BRASS	63719-2
	4M PRE-MILLED BRASS	63719-1
	MATERIAL	PART NO

THIS DRAWING IS A CONTROLLED DOCUMENT.		DWN	L.A.MAYER	9-27-93		Tyco Electronics Corporation	
		CHK	M.S. FEHER	9-27-93		Harrisburg, PA 17105-3608	
DIMENSIONS: mm [INCHES]		TOLERANCES UNLESS OTHERWISE SPECIFIED:		APVD	A.HUNT III	NAME	
		0 PLC	± -	108-1484		PRODUCT SPEC	
		1 PLC	± -	114-2140		APPLICATION SPEC	
		2 PLC	± 0.13 [.005]	A2		SIZE	CAGE CODE
		3 PLC	± -	00779		DRAWING NO	RESTRICTED TO
		4 PLC	± -	G-63719		-	
		ANGLES	± 1°	CUSTOMER DRAWING		SCALE 10:1 SHEET 1 of 1 REV J	
MATERIAL SEE TABLE		FINISH 0.002032 [.000080] MIN TIN PLATE		WEIGHT -			